

✓ Resimde gördüklerimizi anlatalım.

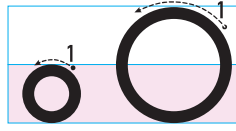

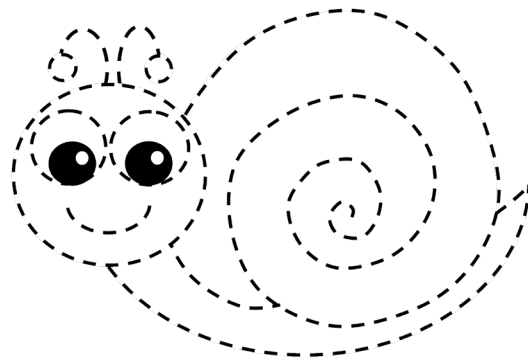

✓ Adında "o" sesi olan görsellerdeki noktaları birleştirip görseli boyayalım.

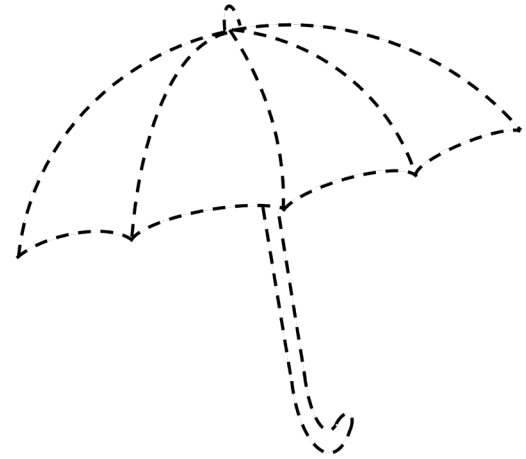
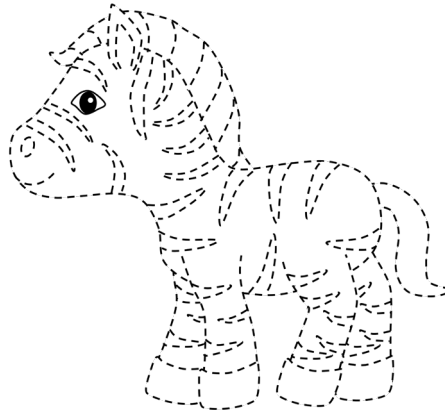
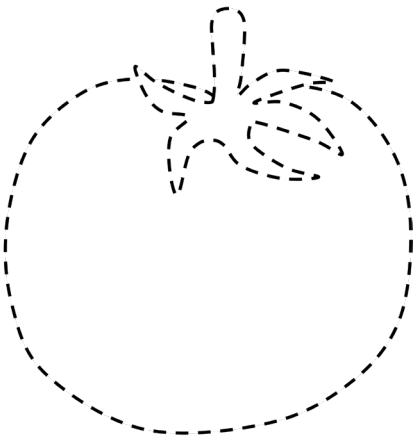
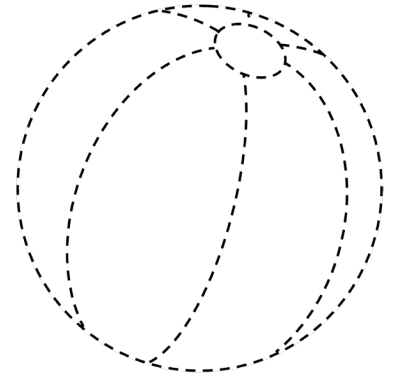
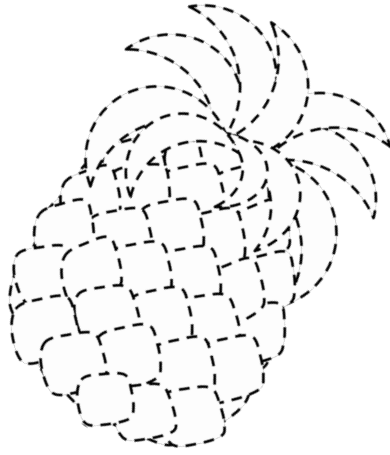
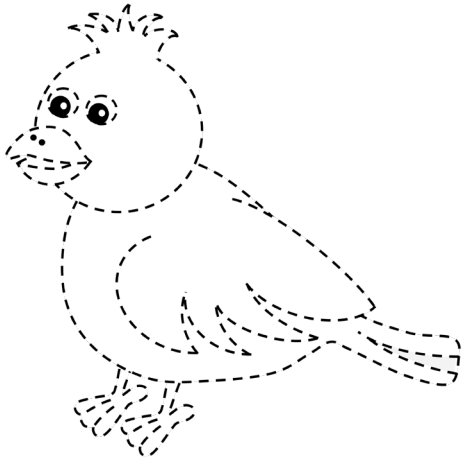
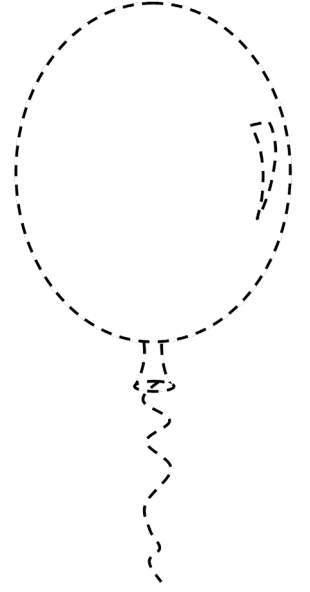
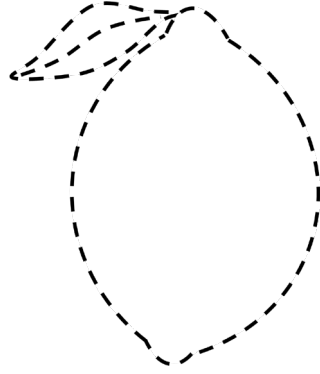
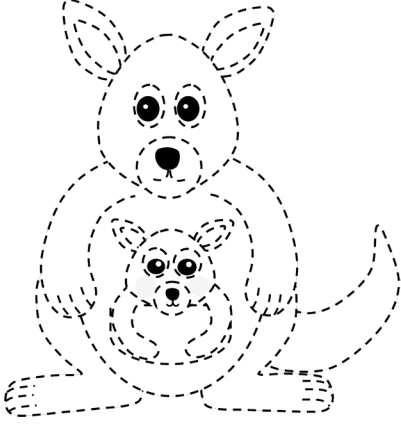

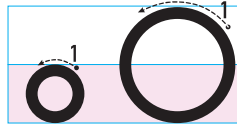

✓ Adında "o" sesi olan varlıkları işaretleyelim.

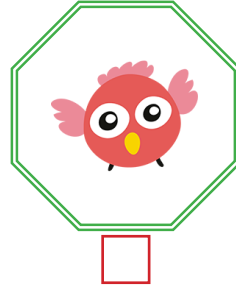
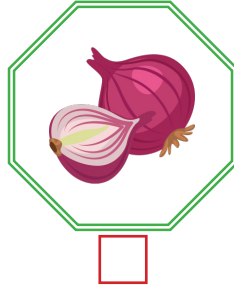
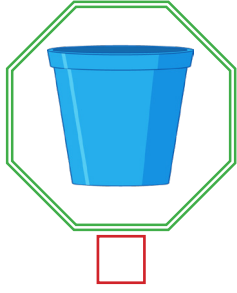
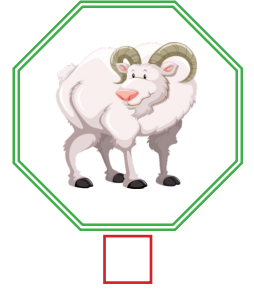
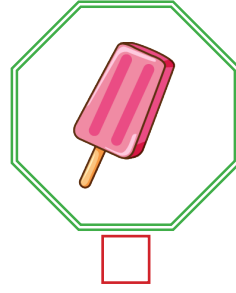
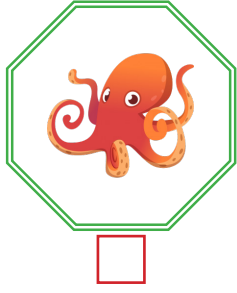
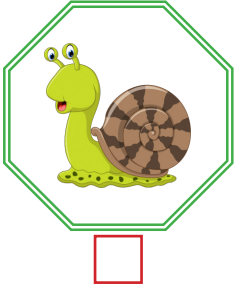
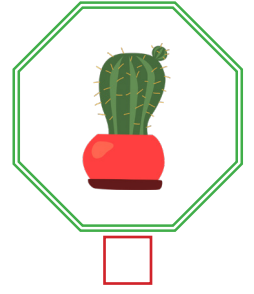
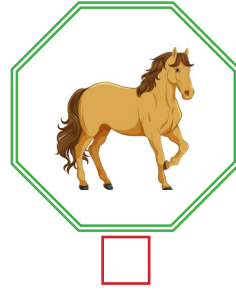
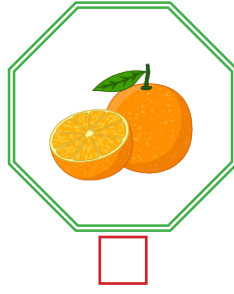
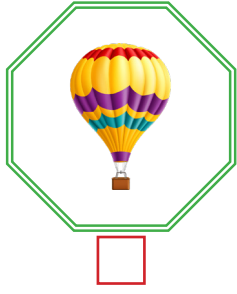
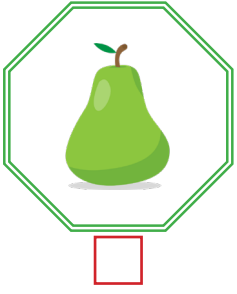

✓ Aşağıdaki görsellerin adında bulunan "o" sesi kadar kalp boyayalım.

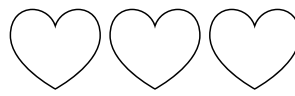
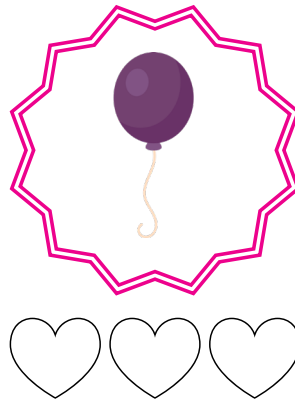
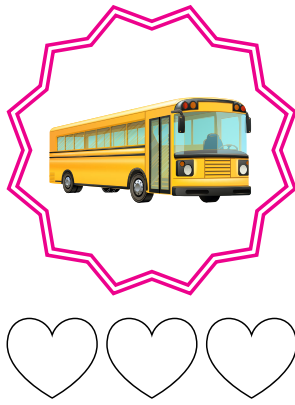

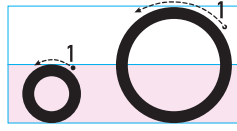

✓ Kalemle kullanarak 1 rakamının bulunduğu yerden başlamak şartıyla ok yönünde "o" harflerini içinden çizerek örnekteki gibi yapalım.

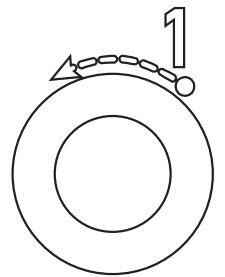
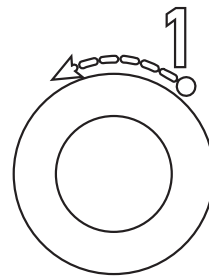
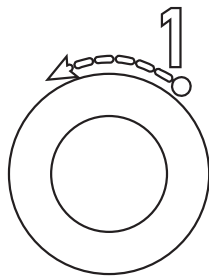
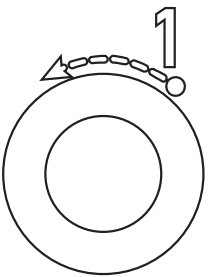
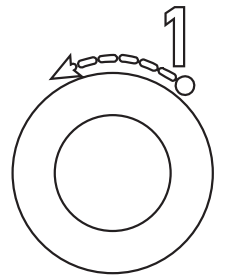
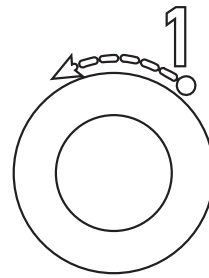
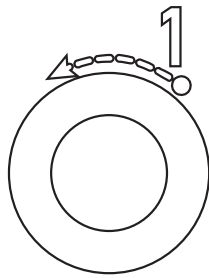
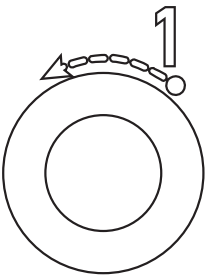
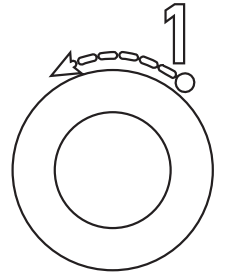
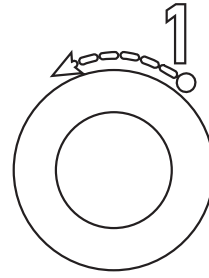
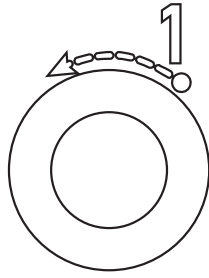
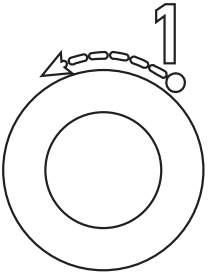
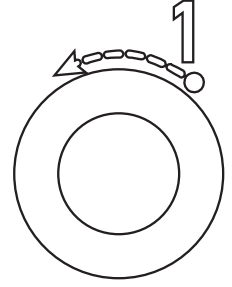
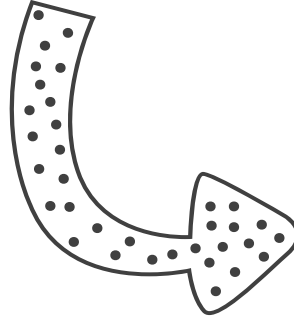
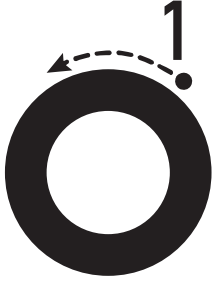

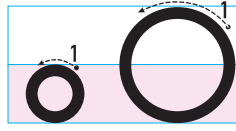

✓ "o" harfini yazalım.



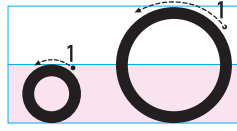

✓ "o" harfini yazalım.

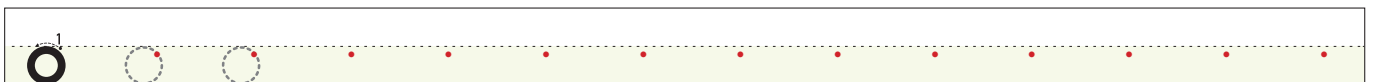
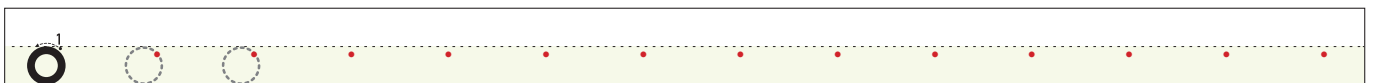
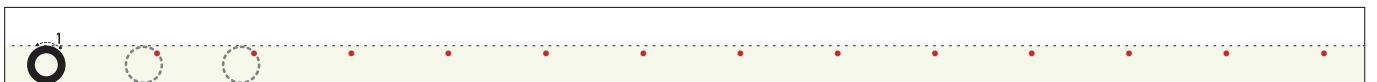
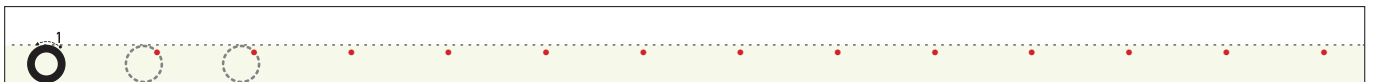
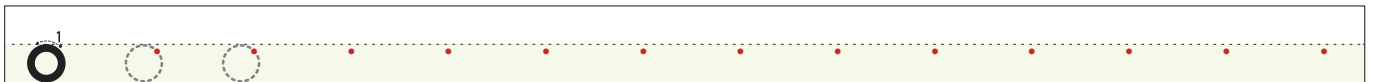
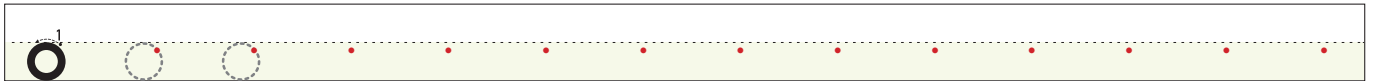
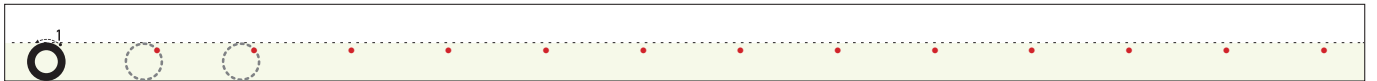
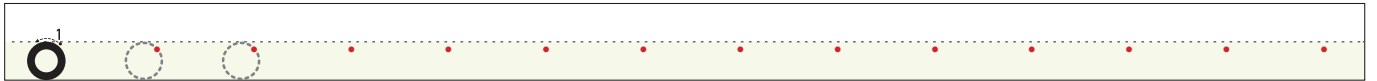
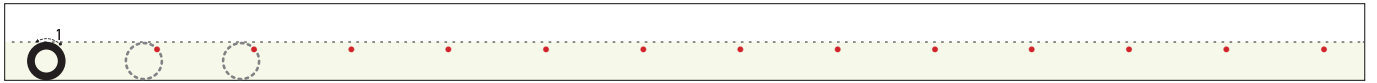
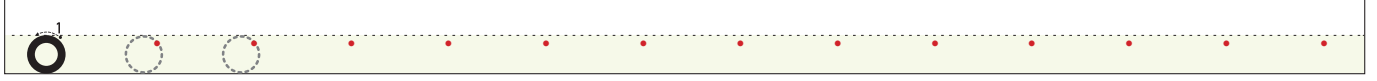
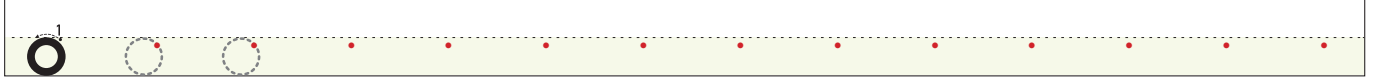

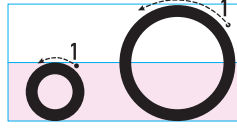

✓ Aşağıdaki satır dizgelerine “o” harfini yazalım.

o o o

o o o

o o o

o o o

o o o

o o o

o o o

o o o

o o o

o o o

o o o

o o o

o o o

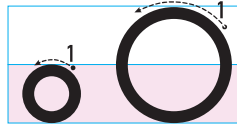

✓ Kalemle kullanarak 1 rakamının bulunduğu yerden başlamak şartıyla ok yönünde "O" harflerini içinden çizerek örnekteki gibi yapalım.

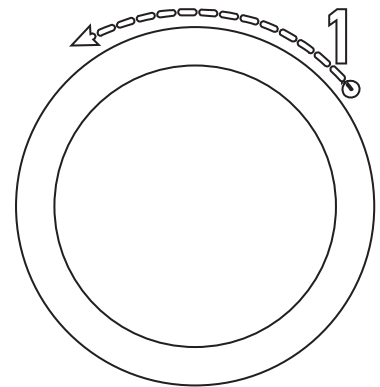
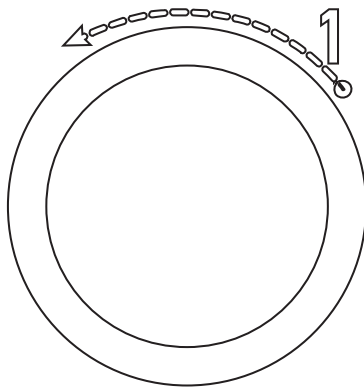
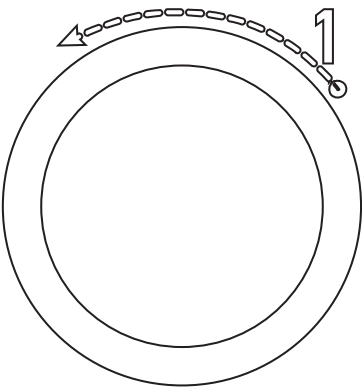
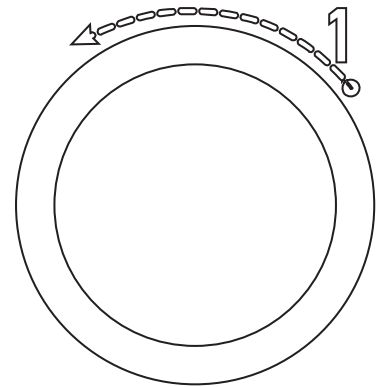
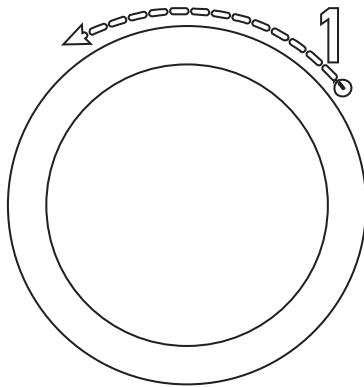
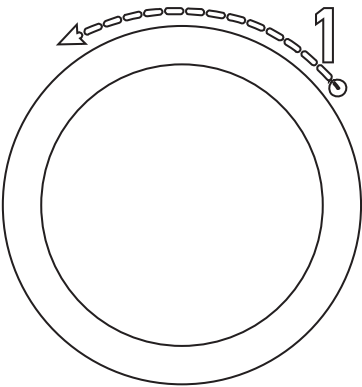
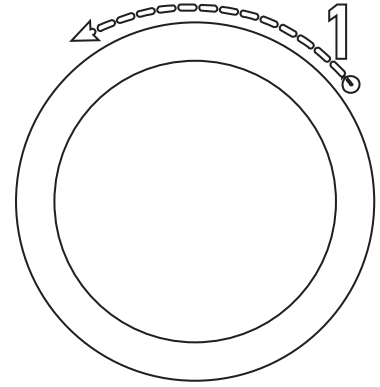
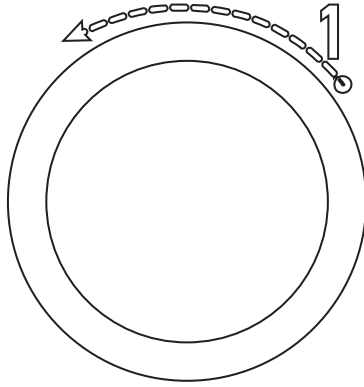
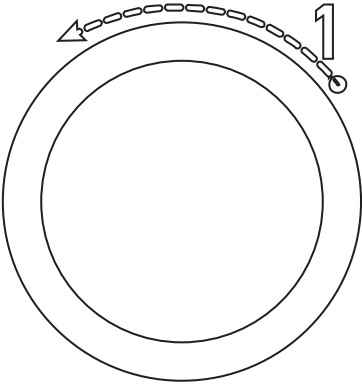
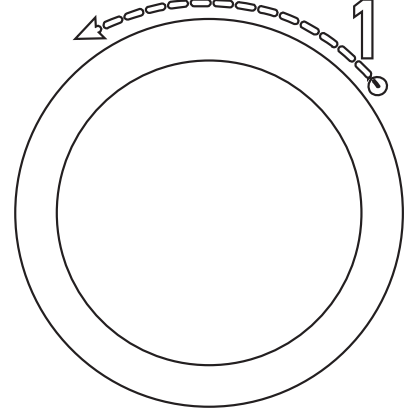
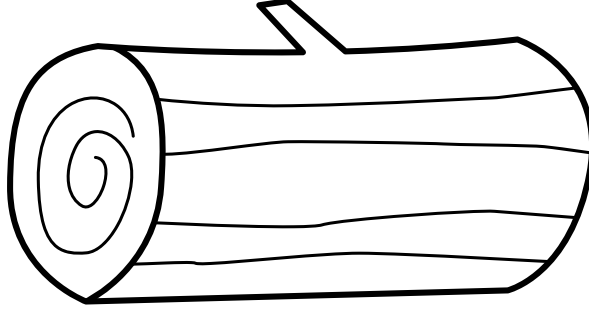
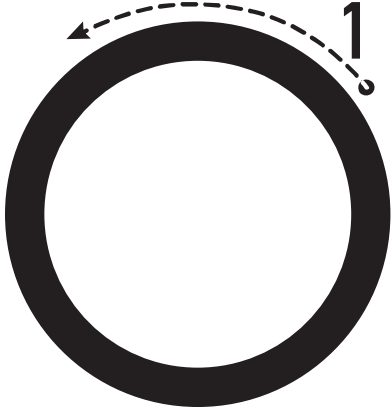

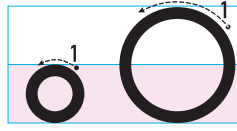

✓ "O" harfini yazalım.

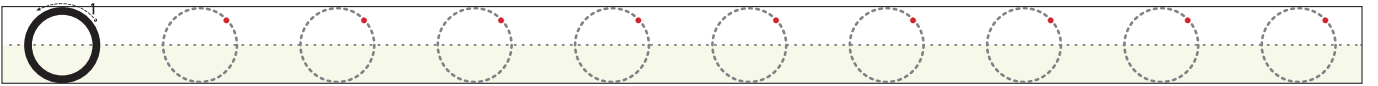
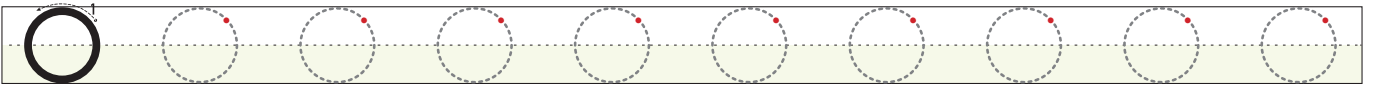
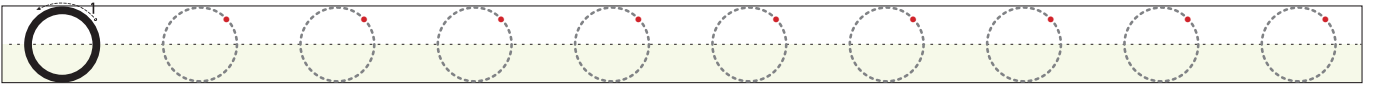
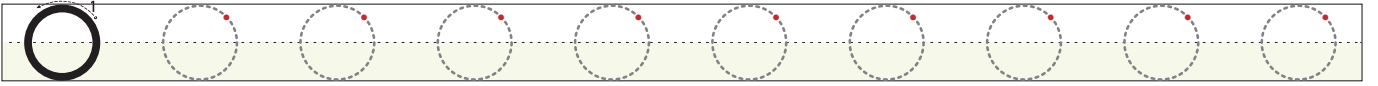
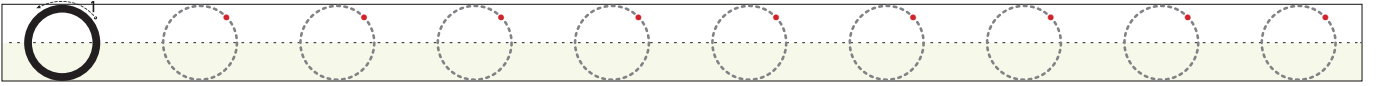

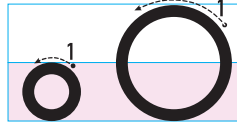

✓ "O" harfini yazalım.

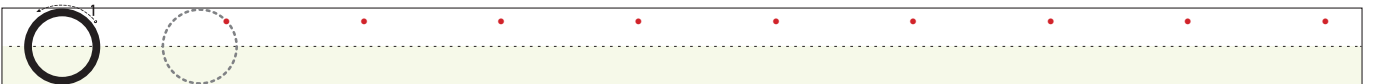
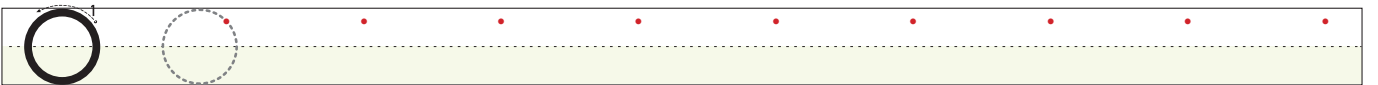
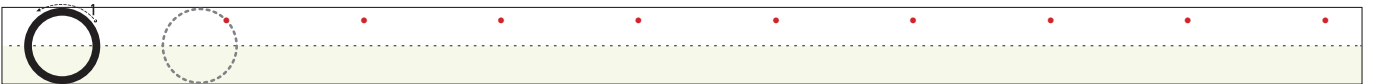
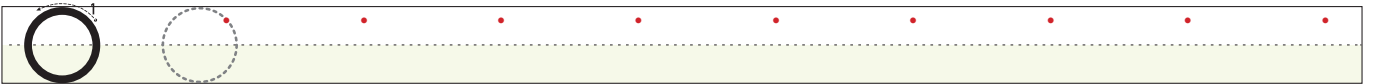
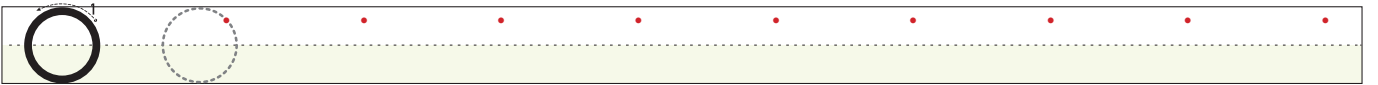
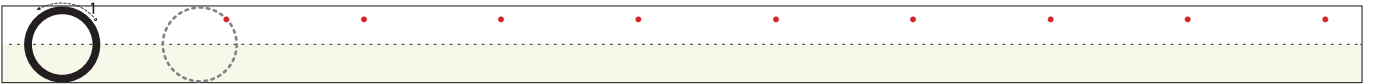
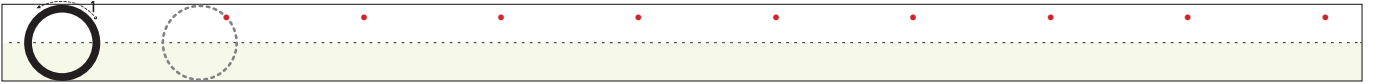
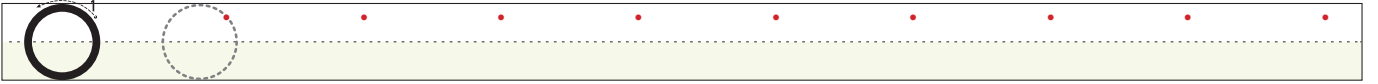
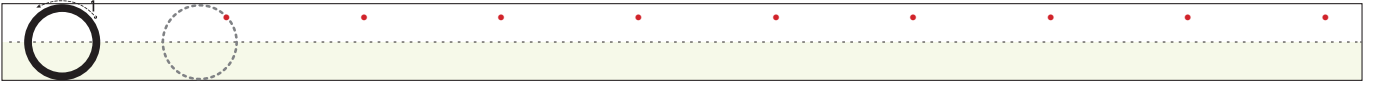
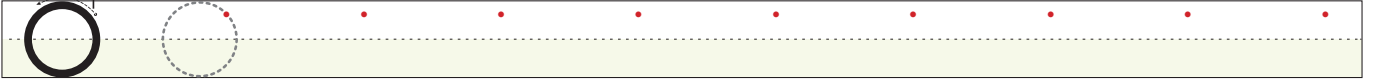

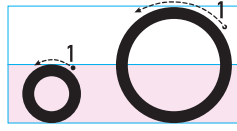

✓ Büyük ve küçük "o" harfini yazalım.

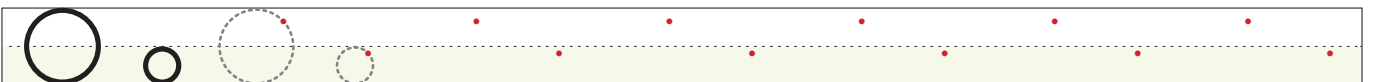
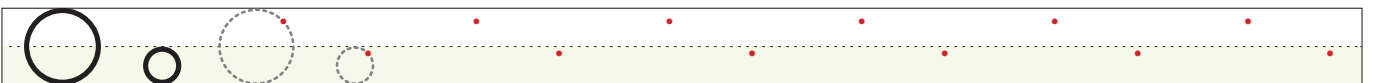
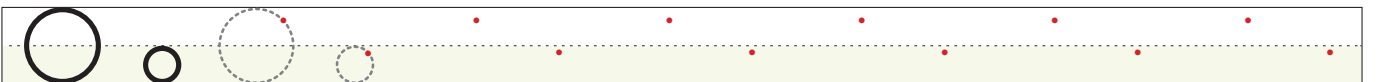
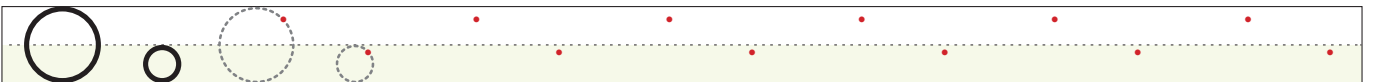
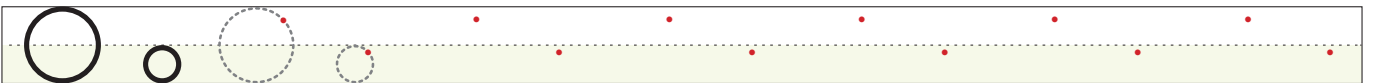
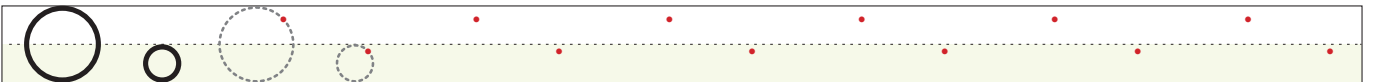
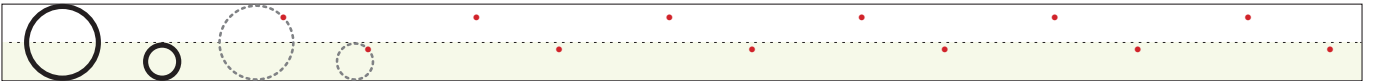
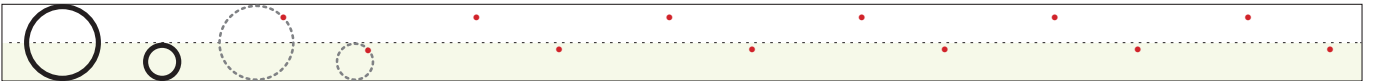
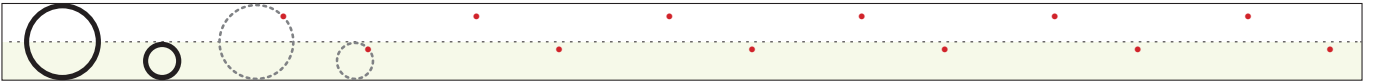
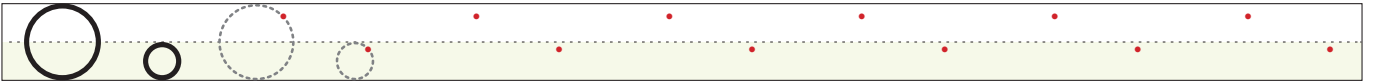
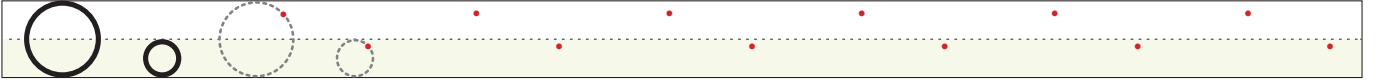
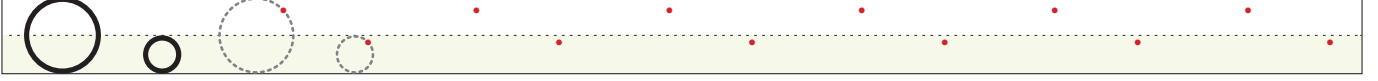
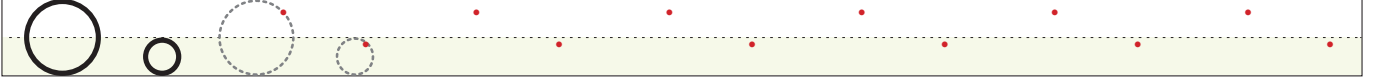

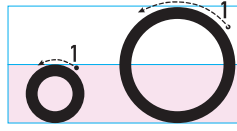

✓ Önce okuyalım, sonra yazalım.

o n on on on on on on on on on on
on on

o t ot ot ot ot ot ot ot ot ot
ot ot

o l ol ol ol ol ol ol ol ol ol
ol ol

n o no no no no no no no no
no no

t o to to to to to to to to
to to

l o lo lo lo lo lo lo lo lo
lo lo

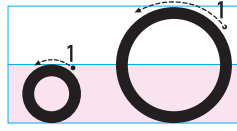

✓ Önce okuyalım, sonra yazalım.

no → t → not not

to → n → ton ton

a → lo → alo alo

o → na → ona ona

o → le → ole ole

no → ta → nota nota

ol → ta → olta olta

o → tel → otel otel

ton → la → tonla tonla

ton → ton → tonton tonton

o → nat → Onat Onat

ot → lat → otlat otlat

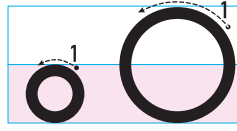

✓ Okuduğunuz sözcüklerin renklerine uygun olarak resmi boyayalım. Boş kalan alanlara boyama yapmayalım.

olta	otel	alo	Onat	ona	Oltan	ole
nota	not	onla	otlat	ton	tonton	on

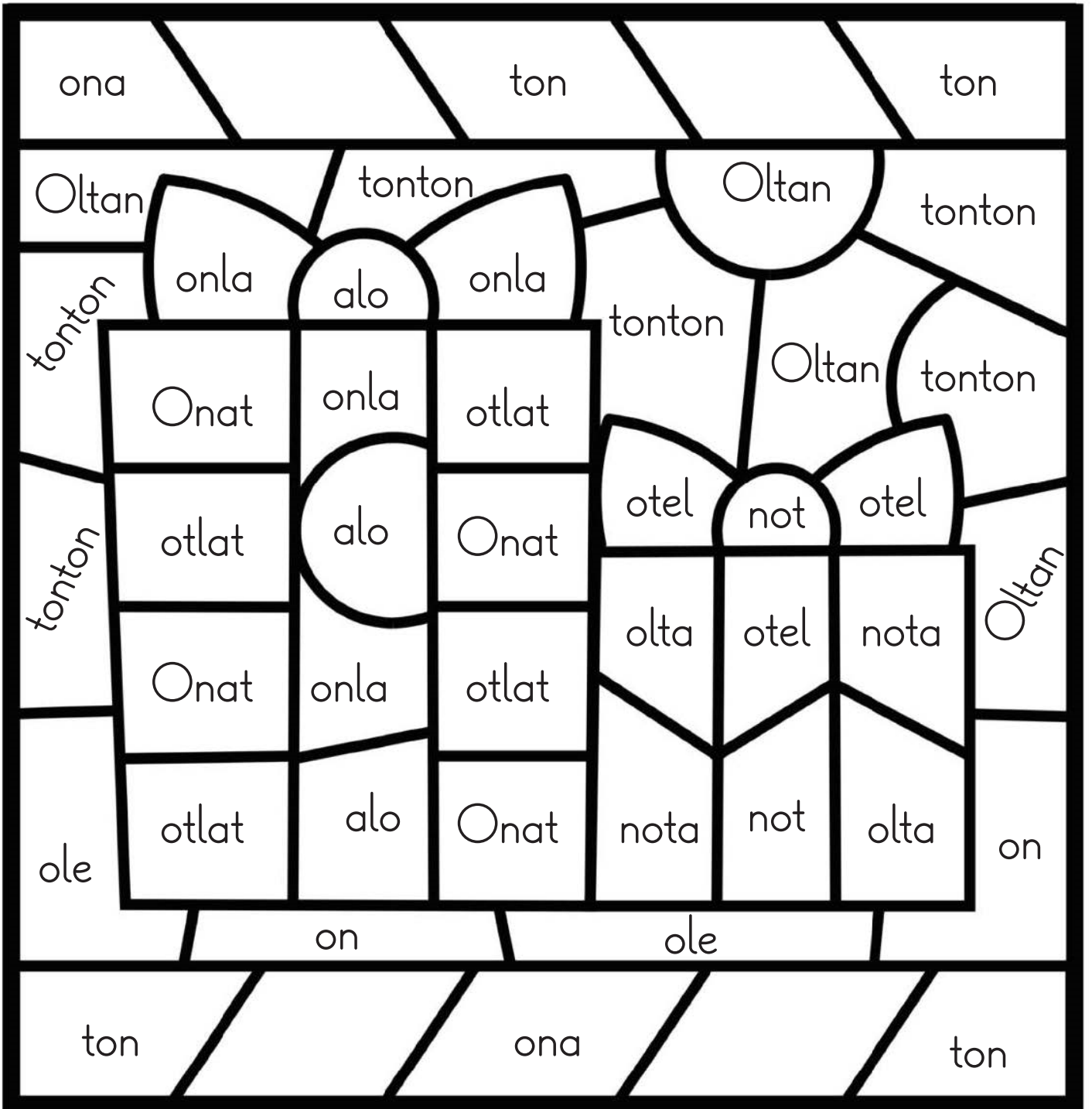

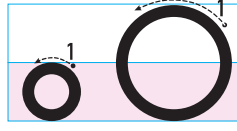

✓ Aşağıdaki tabloda verilen sözcükleri okuyalım. Aynı sözcükleri bulup buldukları kutucukları aynı renge boyayalım.

nota olta tonton otel alo

Onat tel otla not onla

not on nota tonla tonton

ona otla Oltan olta on

lot olta onla otel lon

ton tonla Onat alo on

otlat otel ona lot tonton

Oltan otla lon ton not

ton nota ona otlat on

Onat lot onla tonla Oltan

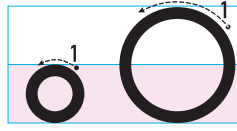

✓ Görseli verilen varlıkların isimlerini yazalım.

10



Blank writing line for the number 10.

Blank writing line for the fishing rod.

Blank writing line for the grass.



Blank writing line for the musical note.

Blank writing line for the swimming pool.

✓ Aşağıda verilen heceleri birleştirerek sözcükler oluşturup yazalım.

ol ta

ot lat

no ta

o na

Blank writing line for the word 'olta'.

Blank writing line for the word 'otlat'.

Blank writing line for the word 'nota'.

Blank writing line for the word 'ona'.

ton la

ton ton

o nat

o tel

Blank writing line for the word 'tonla'.

Blank writing line for the word 'tonton'.

Blank writing line for the word 'onate'.

Blank writing line for the word 'otel'.

lo to

al to

o to

on la

Blank writing line for the word 'loto'.

Blank writing line for the word 'aloto'.

Blank writing line for the word 'oto'.

Blank writing line for the word 'onla'.

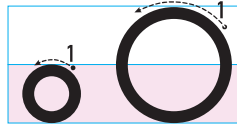

✓ Aşağıdaki cümleleri okuyup uygun görsellerle eşleştirelim.

→ Ali ata ot at.



→ Tonton nine ninni anlat.



→ Onat olta al.



→ Nalan not al.



→ Nail on tane nane al.



→ Oltan ile Ela oto al.



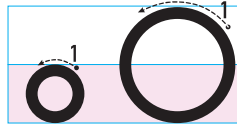

✓ Önce okuyalım, sonra yazalım.

★ Ela ile Onat el ele.

Handwriting practice line with a dashed midline and a yellow shaded bottom area.

★ Nail ona ot al.

Handwriting practice line with a dashed midline and a yellow shaded bottom area.

★ Lale, tonton nineni anla.

Handwriting practice line with a dashed midline and a yellow shaded bottom area.

★ Nalan, telli olta al.

Handwriting practice line with a dashed midline and a yellow shaded bottom area.

★ Oltan on ton ot al.

Handwriting practice line with a dashed midline and a yellow shaded bottom area.

★ Tan, Onat ile otele in.

Handwriting practice line with a dashed midline and a yellow shaded bottom area.

★ Talat on tane lale elle.

Handwriting practice line with a dashed midline and a yellow shaded bottom area.

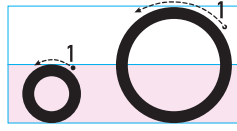

✓ Karışık olarak verilen sözcüklerden anlamlı cümleler oluşturup yazalım.

olta

al

Onat

Blank writing line with a dashed midline and a yellow bottom bar.

Ali

at

ata

ot

Blank writing line with a dashed midline and a yellow bottom bar.

on

lale

al

anne

Blank writing line with a dashed midline and a yellow bottom bar.

✓ Verilen cümlelerdeki noktalı yerleri görsellere bakarak tamamlayalım.

Ali ata at.



Ela on tane olta.



Tonton nine elle.



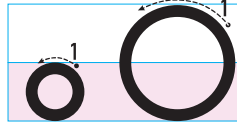

✓ Önce okuyalım, sonra yazalım.

TONTON

Tonton nine o ne?

Oltan o olta.

Tane tane olta.

On tane olta.

Tonton nine olta al.

Onat ile olta al.



Handwriting practice line with a dashed midline and a yellow shaded bottom section.

Handwriting practice line with a dashed midline and a yellow shaded bottom section.

Handwriting practice line with a dashed midline and a yellow shaded bottom section.

Handwriting practice line with a dashed midline and a yellow shaded bottom section.

Handwriting practice line with a dashed midline and a yellow shaded bottom section.

Handwriting practice line with a dashed midline and a yellow shaded bottom section.

Handwriting practice line with a dashed midline and a yellow shaded bottom section.

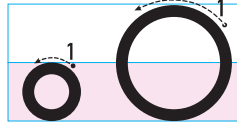

✓ Önce okuyalım, sonra yazalım.

ALO

Alo Lale alo!
Lale not al, ilet.
Otele not ilet.
Annene oteli anlat.
O otel Nalan'a ait.
Annene not ilet.



Blank writing line with a dashed midline and a yellow shaded bottom section.

Blank writing line with a dashed midline and a yellow shaded bottom section.

Blank writing line with a dashed midline and a yellow shaded bottom section.

Blank writing line with a dashed midline and a yellow shaded bottom section.

Blank writing line with a dashed midline and a yellow shaded bottom section.

Blank writing line with a dashed midline and a yellow shaded bottom section.

Blank writing line with a dashed midline and a yellow shaded bottom section.

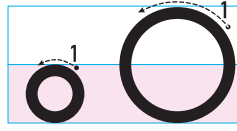

✓ Önce okuyalım, sonra yazalım.

OLTA

Talat olta al.

Talat olta at.

Talat olta al, at.

Talat on olta al.

Al Talat, olta al.

At Talat, olta at.



Handwriting practice line with a dashed midline and a yellow shaded bottom section.

Handwriting practice line with a dashed midline and a yellow shaded bottom section.

Handwriting practice line with a dashed midline and a yellow shaded bottom section.

Handwriting practice line with a dashed midline and a yellow shaded bottom section.

Handwriting practice line with a dashed midline and a yellow shaded bottom section.

Handwriting practice line with a dashed midline and a yellow shaded bottom section.

Handwriting practice line with a dashed midline and a yellow shaded bottom section.